

DCP-X05 Manual (PELCO/VISCA™ PTZ-Camera-Controller)

Art.-No. DCP-X05

X1 CAM POWER:

Pin	Name/Function
X1.1	+8...32V output 1A (switched*)
X1.2	+8...32V output 1A
X1.3	GND

* VISCA™ command *Cam_Power On/Off*
connector: JST-SHR-03V-S-B
flex: pre-crimped wire JST-SH3-SH3-28300

X2 MAIN I/O:

Pin	Name/Function
X2.1	POWER1 +8...32V priority-input
X2.2	GND
X2.3	video output (connect. to X4.1)
X2.4	PELCO RS485-A (conn.to X7.7)
X2.5	PELCO RS485-B (conn.to X7.8)

connector: WR-WTB 2.0mm 620005113322
flex: WR-WTB pre-crimped wire 620120124030
RS485: 9600 baud,8 databits, no parity,1 stopbit

X3 POWER2:

Pin	Name/Function
X3.1	POWER2 +8...32V input
X3.2	GND

connector: WR-WTB 2.0mm 620002113322
flex: WR-WTB pre-crimped wire 620120124030

X4 CAM VIDEO:

Pin	Name/Function
X4.1	video input (connected to X2.3)
X4.2	GND

connector: JST-SHR-02V-S-B
flex: pre-crimped wire JST-SH3-SH3-28300

X5 PT-MOTORS:

Pin	Name/Function
X5.1	PAN left, 8...32V, ≤ 3A
X5.2	PAN right, 8...32V, ≤ 3A
X5.3	TILT down, 8...32V, ≤ 3A
X5.4	TILT up, 8...32V, ≤ 3A

connector: WR-WTB 2.0mm 620004113322
flex: WR-WTB pre-crimped wire 620120124030

X6 PT-PRESETS:

Pin	Name/Function
X6.1	+2.048V output, ≤ 2mA
X6.2	GND
X6.3	PAN preset-potentiometer
X6.4	TILT preset-potentiometer

connector: JST-SHR-04V-S-B
flex: pre-crimped wire JST-SH3-SH3-28300

fig 2 - X6 PT-PRESETS

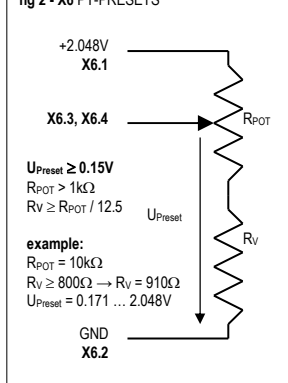

X7 SERIAL COMMUNICATION:

Pin	Name/Function
X7.1	VISCA RS232 TxD
X7.2	VISCA RS232 RxD
X7.3	GND
X7.4	VISCA TTL 3.3V TxD
X7.5	VISCA TTL 3.3V RxD (5V tol.)
X7.6	GND
X7.7	PELCO RS485-A (conn.to X2.4)
X7.8	PELCO RS485-B (conn.to X2.5)

connector: JST-SHR-06V-S-B
flex: pre-crimped wire JST-SH3-SH3-28300
RS485: 9600 baud,8 databits, no parity,1 stopbit
RS232: 9600 baud,8 databits, no parity,1 stopbit

VISCA™ is a trademark of SONY Corporation

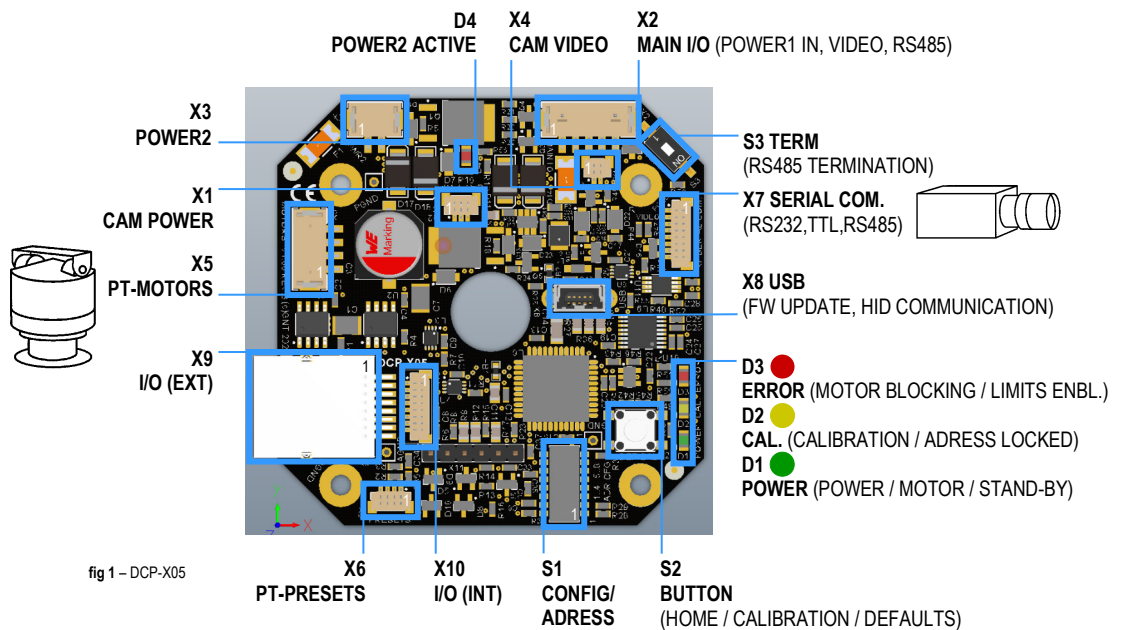

fig 1 - DCP-X05

X8 USB:

Function
USB 2.0, bus powered (max 100mA), Mode=Device, HID Communication, FW Update

S3 TERM:

Pin	Name/Function
OFF*	RS485 120Ω termination
ON	RS485 no termination

* default

S1 CONFIG/ADDRESS:

Switch	OPEN/CLOSED	Name/Function
SW1.1 ...	OFF* = 0 ON = 1	VISCA (SW1.4 = don't care) SW1.3...1.1 = 000 = VISCA™ address 81h by default and can be changed at any time with VISCA™ AddressSet command (dynamic) SW1.3...1.1 = 001...111 = VISCA™ address locked to 81h...87h PELCO: SW1.4...1.1 = 0000...1111 = PELCO address
SW1.5 (RANGE)	OFF* ON	VISCA: pan-tilt angle congruently to SONY EVI-D31 angle, zoom address range 0...1023 (03FFh) VISCA: full pan-tilt angle (360°/180°) with SONY EVI-D31 pt-address range, zoom address range 0...16368 (3FF0h)
SW1.6 (MODE)	OFF* ON	VISCA: VISCA™ address +1: no external FCB-xxx camera connected PELCO: no external FCB-xxx camera connected VISCA: VISCA™ address +0: FCB-xxx camera next in VISCA™ chain PELCO: external FCB-xxx camera connected
SW1.7 future use	OFF* ON	reserved
SW1.8 future use	OFF* ON	reserved

* default

power OFF→ON or send VISCA™ *Cam_Power Off/On* or *IF_Clear* command after any change of switch position

S2 BUTTON:

Condition	Action	Comment
Press BUTTON S2 before and hold button during power ON from POWER1 (MAIN I/O X2) or POWER2 (X3). USB (X8) must not be connected!	reset to DEFAULTS (D1, D2, D3 are fast blinking during reset) Do not disconnect power while LEDs are blinking!	Resets the following settings: PWM min. values for low speed (pan-tilt), virtual limits (pan-tilt) not active, <i>cam_custom</i> register (power ON at power-up), PELCO address (equals switches SW1.1 ... SW1.4)
Press BUTTON S2 before and hold button while connecting DCP-X05 to a PC via USB (X8). POWER1 (X2) and POWER2 (X3) must not be connected!	start HID bootloader for FW UPDATE via USB (X8). LEDs D1 (green) and D3 (red) are on while the bootloader is active.	Bootloader allows connection to the Windows PC <i>FW Update Tool</i> within 5 seconds. After 5 seconds with no connection (button "CONNECT" in FW Update Tool software not pressed), the HID bootloader starts the DCP-X05 Firmware.
after power ON: press and hold BUTTON S2 for >10 seconds. USB (X8) must not be connected!	CALIBRATION (yellow D2 ON)	preset-potentiometers must be connected before CALIBRATION
press 1x short USB (X8) must not be connected!	HOME position	moves the pt-head to the home position if preset-potentiometers are available

X9 I/O (EXT):

Pin	Name/Function
X9.1	connected to X10.1
X9.2	connected to X10.2
X9.3	connected to X10.3
X9.4	connected to X10.4
X9.5	connected to X10.5
X9.6	connected to X10.6
X9.7	connected to X10.7
X9.8	connected to X10.8

connector: RJ-45 8/8

X10 I/O (INT):

Pin	Name/Function
X10.1	connected to X9.1
X10.2	connected to X9.2
X10.3	connected to X9.3
X10.4	connected to X9.4
X10.5	connected to X9.5
X10.6	connected to X9.6
X10.7	connected to X9.7
X10.8	connected to X9.8

connector: JST-SHR-08V-S-B
flex: pre-crimped wire JST-SH3-SH3-28300

D1 POWER (LED green):

ON	OFF	Name	Function
∞	0s	100% ON	<i>Cam_Power On</i>
0.4s	0.4s	slow blinking	any MOTOR ON
0.1s	0.1s	fast blinking	-
50ms	1s	flashing	<i>Cam_Power Off</i> (stand-by)

D2 CALIBRATION (LED yellow):

ON	OFF	Name	Function
∞	0s	100% ON	CALIBRATION active
0.4s	0.4s	slow blinking	BUTTON pressed → counting 10s to start calibration!
0.1s	0.1s	fast blinking	-
50ms	1s	flashing	VISCA™ address LOCKED

D3 ERROR (LED red):

ON	OFF	Name	Function
∞	0s	100% ON	-
0.4s	0.4s	slow blinking	-
0.1s	0.1s	fast blinking	any motor BLOCKING (only with presets)
50ms	1s	flashing	virtual limit switches (pan, tilt) are enabled

D4 POWER2 ACTIVE (LED red):

ON	OFF	Name	Function
∞	0s	100% ON	POWER2 active (if priority-input POWER1 (X2 MAIN I/O) is not connected to a power-supply)

USB FW Update

- If you are using the PC to update the firmware on the DCP-X05 for the very first time it may be useful to install the USB HID driver first. Simply connect the DCP-X05 with a mini-USB cable to the PC and wait until the USB HID driver is automatically installed.
- Remove all connection cables from the DCP-X05 controller.
- Run the 'mikroBootloader USB HID.exe' application (supplied by GNT) on a MS Windows 10 (or compatible) PC with USB support.
- Press and hold the **BUTTON S2** on DCP-X05.
- Connect the DCP-X05 to the PC with a mini-USB cable while keeping the **BUTTON S2** pressed. (green and red LEDs are ON to signal that USB firmware update HID bootloader is active).
- Within 5 seconds after the USB connection with the USB cable is made, click the 'Connect' button in the 'mikroBootloader USB HID.exe' application (the DCP-X05 bootloader automatically exits after 5 seconds if no connection is made with the 'Connect' button).
- Select the new DCP-X05... .hex firmware file.
- Click the 'Upload' button in the 'mikroBootloader USB HID.exe' application. **DO NOT DISCONNECT THE USB CABLE WHILE UPLOADING!**
- The firmware is uploaded to the DCP-X05 controller and the device restarts with the new firmware.
- Remove the USB cable

Priority-Power (POWER1 priority-input and POWER2 input)

Power inputs POWER1 (X2 MAIN I/O) and POWER2 (X3 POWER2) are two alternative power inputs for power-supplies with a voltage level range of 8..32V DC. If both inputs are connected to a power-supply, than POWER1 priority-input will automatically selected regardless of if the voltage level at input POWER1 is lower than the voltage level at input X3 POWER2.

If only POWER2 is connected, the red LED **D4 POWER2 ACTIVE** is on.

fig 3 - Simultaneous Control from PELCO and VISCA™ Interface

It is possible to control the pan-tilt head and the connected FCB-xxx camera from the PELCO interface (RS485) and the VISCA™ interface (RS232) simultaneously.

Please note that if an external FCB-xxx camera is connected to the RS232 Interface in a daisy-chain configuration (as shown below), the DCP-X05 cannot receive replies from the FCB-xxx camera. Only the VISCA™ master (the computer "2" below) can receive these replies. Therefore it is i.e. not possible to query the zoom-position from the RS485 PELCO interface if the FCB-xxx camera is not connected directly to the DCP-X05 (as it is shown in fig 6).

However, if the DCP-X05 cannot read the zoom-position from the camera (timeout=1000ms if the DCP-X05 does not receive a reply from the connected FCB-xxx camera), it will reply to zoom-queries with the last direct zoom-position that has been sent to the DCP-X05 before (or with 0000h if no zoom direct command has been received since power-up).

The VISCA™ address is either dynamic (SW1.3 ... 1.1 = binary 000) or 81h (SW1.3 ... 1.1 = binary 001...111). SW1.4 is don't care for VISCA™ address configuration.

The PELCO address equals the switches SW1.4 ... 1.1 (binary 0000 ... 1111 = 0 ... 15).

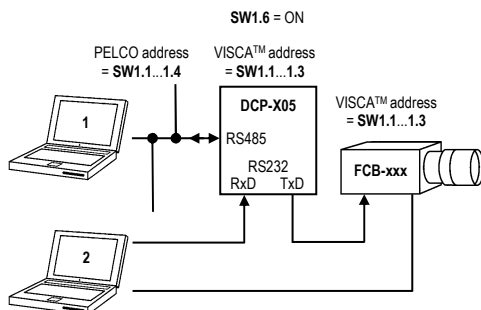

fig 4 - VISCA™ Communication (SW1.6 (MODE) = ON; with external FCB-xxx camera)

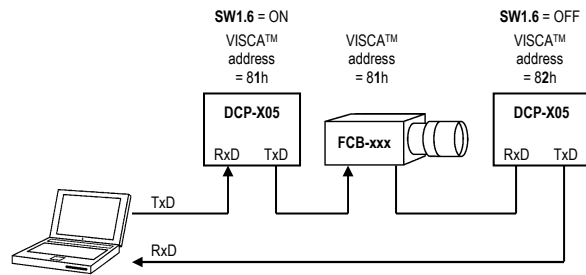

fig 5 - RS232 VISCA™ system ID message at power ON (with locked VISCA™ address)

```
"GNT 2020 DCP-X05 FW V1.00 VISCA-ADR=0x81(LOCKED)
PELCO-ADR=0x01(DIPSW) DIPSW-S1=0x01"
```

```
VISCA-ADR=0x81(LOCKED)
PELCO-ADR=0x01(DIPSW)
DIPSW-S1=0x01
```

```
VISCA Address = 0x81..0x87 (LOCKED / UNLOCKED)
Pelco Address = 0x00..0xFF (DIPSW / EEPROM)
DIP Switches S1 = SW1.8..SW1.1 = 0x00..0xFF
```

RS232 VISCA™ Addressing (RS232)

The VISCA™ address can be assigned with the *AddressSet* command or locked to a specific address with the switches **SW1.3...SW1.1**.

If the switches **SW1.3...SW1.1** are all OFF (SW1.3...SW1.1 = binary 000 = 00h), the VISCA™ address is 81h by default and can be changed at any time to 81h...87h with the VISCA™ *AddressSet* command.

If the switches **SW1.3...SW1.1** are not all OFF, the VISCA™ address of the DCP-X05 equals the position of the switches + 80h (i.e. if the switches **SW1.1** and **SW1.2** are ON, the VISCA™ address is: 03h (binary 011) + 80h = 83h. The switch **SW1.4** is ignored and should be set to 0 (OFF) for VISCA™ communication.

fig 6 - PELCO Communication (SW1.6 (MODE) = ON; with external FCB-xxx camera)

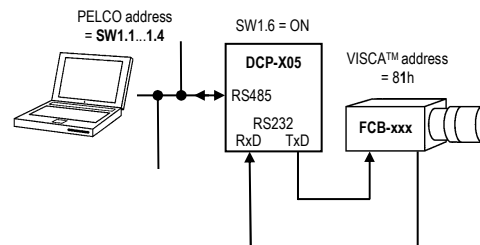

fig 7 - RS485 PELCO Query response

```
FfH 01h „DCPX5 1.0 001 1“ 5Ch
```

```
FfH Sync Byte
01h Pelco Address (hex)
„DCPX5“ Product ID
„1.0“ FW-Version
„001“ Pelco Address (decimal)
„1“ Number of detected VISCA™ devices (i.e. 1 as shown in fig 6)
5Ch Checksum
```

fig 8 - RS485 PELCO Addressing

The PELCO address may be assigned with the switches **SW1.4 ... SW1.1** or with a modified PELCO *Query* command within 5 seconds after power-up.

If no PELCO address has been assigned with the modified PELCO *Query* command (or the assigned PELCO address in the modified PELCO *Query* command is 00h), the PELCO address of the DCP-X05 equals the state of the switches **SW1.4 ... SW1.1** (binary 0000 ... 1111 = 00h ... 0Fh = PELCO address 0 ... 15)

A modified PELCO *Query* command can be send within 5 seconds after power-up to assign a new PELCO address to the DCP-X05:

```
FfH 00h 00h 45h 45h NewAddress Checksum
```

(i.e. assigning PELCO address **03h** to the DCP-X05: send PELCO FfH 00h 00h 45h 45h **03h** 8Dh)

The switches **SW1.4 ... SW1.1** will then be ignored regarding the PELCO address and the new assigned PELCO address will be used. The new address is stored in the DCP-X05 EEPROM and does not need to be set again after power-up. If the PELCO address **00h** is assigned to the DCP-X05 controller with the modified PELCO *Query* command, the switches **SW1.4 ... SW1.1** will again determine the PELCO address.

VISCA™ Commands (X7 VISCA – RS232)
VISCA™ Management

Packet (Hex)	Description
AddressSet 88 30 01 FF	DCP-X05 (VISCA™ network) replies with 88 30 0x FF if the VISCA™ address is <u>not</u> locked (D2 not flashing): SW1.6 OFF : x = number of VISCA™ instances (max. 6) + 1 (i.e. 2, 3, 4, 5, 6, 7) SW1.6 ON : x = number of VISCA™ instances (max. 7) + 0 (i.e. 1, 2, 3, 4, 5, 6, 7) if the VISCA™ address is locked (D2 flashing): SW1.6 OFF : x = locked VISCA™ address – 80h + 1 (i.e. 2, 3, 4, 5, 6, 7) SW1.6 ON : x = locked VISCA™ address – 80h + 0 (i.e. 1, 2, 3, 4, 5, 6, 7)
IF_Clear 8x 01 00 01 FF 88 01 00 01 FF (broadcast)	restart: system reset, VISCA™ interface reset (except for VISCA™ address) and error status. DCP-X05 replies with X0 50 FF or 88 01 00 01 FF (broadcast) note : reply packet must be awaited before sending a new data packet
Command Cancel 8x 2y FF	Cancel current command (i.e. <i>Pan-tilt_Drive AbsolutePosition</i>) reply: X0 6y 04 FF (command in socket y is canceled) X0 6y 05 FF (no command in socket or command has already been completed)

x = 1 to 8 (VISCA address)
X = 9 to F (VISCA address + 8)
y = socket number (1 or 2)

Error Messages

Error Packet (Hex)	Type	Comments
X0 6y 02 FF	Syntax Error	VISCA™ syntax error or function not supported by DCP-X05
X0 60 03 FF	Command Buffer Full	a) both command sockets full b) active calibration
X0 6y 04 FF	Command Canceled	command in socket y is canceled
X0 6y 05 FF	No Socket	no command in socket or command has already been completed
X0 6y 41 FF	Execution Error	a) preset-potentiometers not available for execution of command or relative positioning not available because absolute positioning is currently being executed b) VISCA™ (RS232) timeout: time between characters > 500ms (y=0, no socket) c) address range for pan- and tilt-command exceeded (i.e. if RANGE switch SW1.5 is ON and a tilt-command with address range >012Ch is received)
X0 6y 09 FF	Blocking Error	motor blocking detected (only available with preset-potentiometers)

X = 9 to F (VISCA address + 8)
y = socket number (1 or 2, 0=no socket)

Reply Messages

Reply Packet (Hex)	Note
Ack X0 4y FF	y = socket number (1 or 2)
Completion (Commands) X0 5y FF	y = socket number (1 or 2)
Information Return X0 50 ... FF	

X = 9 to F (VISCA address + 8)
y = socket number (1 or 2)

System

Command Set	Command	VISCA Packet (Hex)	Comments
Cam_Custom	Reset	8x 01 04 3F 00 7F FF	Stores and recalls current <i>Cam_Power On/Off</i> status in internal EEPROM. Status is recalled when DCP-X05 is connected to power source can be reset to defaults with S2 (press and hold during power ON); default state: <i>Cam_Power : On</i>
	Set	8x 01 04 3F 01 7F FF	
	Recall	8x 01 04 3F 02 7F FF	
Cam_Power	On	8x 01 04 00 02 FF	X1.1 On (8...32V)
	Off	8x 01 04 00 03 FF	X1.1 Off, pan- and tilt -motor stop (stand-by)
Cam_Preset	Reset	8x 01 04 3F 00 ZZ FF	<p>ZZ: 00h..63h saves, resets and recalls pan-, tilt- and zoom-position.</p> <p>Because the DCP-X05 cannot receive replies from a connected FCB-xxx camera directly if connected in a VISCA™ daisy-chain (see page no.2 fig 4), the DCP-X05 will store the zoom-position of the <u>last received <i>Cam_Zoom Direct</i> command</u> that has been forwarded to the VISCA™ camera with the same VISCA™ address as the DCP-X05 itself if switch SW1.6 (MODE) is on.</p> <p>(external FCB-xxx camera ZZ: focus, iris.. only with ZZ=0..5h)</p> <p>Presets ZZ = 00h..63h (first 100 presets) are normal presets for the current pan-, tilt- and zoom-position. Presets 64h(100) and 65h(101) are special presets which store the current pan- and tilt-position as a virtual limit-switch. The DCP-X05 controller will not drive the pan-tilt-head above these positions if presets 100 or 101 have been set (red LED D3 is flashing).</p> <p>ZZ = 64h is the virtual limit switch for the maximum LEFT and DOWN position ZZ = 65h is the virtual limit switch for the maximum UP and RIGHT position</p> <p>Virtual limit switches are activated with the <i>Cam_Preset Set</i> command (current position) and deactivated with the <i>Cam_Preset Reset</i> command.</p> <p>The red "ERROR" LED D3 flashes if virtual limit switches are enabled.</p> <p>Virtual limit switches are automatically stored in internal EEPROM of DCP-X05 when set</p>
	Set	8x 01 04 3F 01 ZZ FF	
	Recall	8x 01 04 3F 02 ZZ FF	

x = 1 to 8 (VISCA address)

Commands PT-Head

Command Set	Command	VISCA Packet (Hex)	Comments
Pan-tilt_Drive	Up	8x 01 06 01 VV WW 03 01 FF	VV : pan speed 01h...18h
	Down	8x 01 06 01 VV WW 03 02 FF	WW : tilt speed 01h...14h
	Left	8x 01 06 01 VV WW 01 03 FF	
	Right	8x 01 06 01 VV WW 02 03 FF	
	UpLeft	8x 01 06 01 VV WW 01 01 FF	
	UpRight	8x 01 06 01 VV WW 02 01 FF	
	DownLeft	8x 01 06 01 VV WW 01 02 FF	
	DownRight	8x 01 06 01 VV WW 02 02 FF	Stop halts pan- and tilt axes. (by way of derogation from emulated EVI-D30/31 camera).
	Stop	8x 01 06 01 VV WW 03 03 FF	
	Home*	8x 01 06 04 FF	pan: middle-position tilt: middle-position
Reset**	8x 01 06 05 FF	calibration of pan- and tilt-axis if preset-potentiometer available *** <u>note</u> : voltage on preset-pins must be > 0.15V for preset-potentiometer detection (see page no.1 fig 2)	
RelativePosition*	8x 01 06 03 VV WW 0Y 0Y 0Y 0Y 0Z 0Z 0Z 0Z FF	YYYY : pan axis: relative distance to current pan position 0000h : no change F3A0h...0C60h (-360°...+360°) ZZZZ : tilt axis: relative distance to current tilt position 0000h : no change F790h...0870h (-180°...+180°)	
AbsolutePosition*	8x 01 06 02 VV WW 0Y 0Y 0Y 0Y 0Z 0Z 0Z 0Z FF	SW1.5 OFF : YYYY : pan position 0000h : center F9D0h...0630h (-180°...+180°) ZZZZ : tilt position 0000h : center FBC8h...0438h (-90°...+90°) SW1.5 ON : YYYY : pan position 0000 : center FC90h...0370h (-180°...+180°) ZZZZ : tilt position 0000 : center FED4h...012Ch (-90°...+90°)	
PhysicalPosition (relative)*	8x 01 06 07 VV WW 0Y 0Y 0Y 0Y 0Z 0Z 0Z 0Z FF	YYYY : pan position 0000h...0FFFh ZZZZ : tilt position 0000h...0FFFh	
PhysicalPosition (absolute)*	8x 01 06 08 VV WW 0Y 0Y 0Y 0Y 0Z 0Z 0Z 0Z FF	YYYY : pan position 0000h...0FFFh ZZZZ : tilt position 0000h...0FFFh	
Pan-tilt_PwmMin	Set	8x 01 05 03 VV WW YY ZZ FF	VV : pan left min. PWM 00h...64h WW : pan right min. PWM 00h...64h (PWM: 0...100% pulse width) YY : tilt down min. PWM 00h...64h ZZ : tilt up min. PWM 00h...64h (PWM: 0...100% pulse width) <i>Pan-tilt_PwmMin</i> is automatically stored in the internal EEPROM of the DCP-X05 when <i>Pan-tilt_PwmMin</i> command is received can be reset to defaults with S2 (press and hold during power ON): VV : 1Ch (28%), WW : 1Dh (29%) YY : 1Ch (28%), ZZ : 1Ch (28%)

x = 1...8 (VISCA™ address – see VISCA™ Management)

* only with preset-potentiometer

** no VISCA™ commands are accepted during calibration

Commands ZFI-Lens

Command Set	Command	VISCA Packet	Comments
<i>Cam_Zoom</i>	Direct*	8x 01 04 47 0Z 0Z 0Z 0Z FF	SW1.5 ON: ZZZZ : to FCB-xxx camera is rescaled (03FF → 3FF0)

x = 1...8 (VISCA™ address – see VISCA™ Management)

* only with preset-potentiometer

** no VISCA™ commands are accepted during calibration

VISCA™ Inquiries

Inquiries System

Inquiry	Packet Inquiry (Hex)	Packet Reply (Hex)	Description
<i>Cam_VersionInq</i>	8x 09 00 02 FF	X0 50 ij kl mn pq rs tu vw FF	ijkl : 0F0Fh (Vendor ID = GNT); mnpq : 0402h (Model = SONY EVI-D31); rstu : 0100h (DCP-X05 FW Vers. = 1.0); vw : 02h (Number of Sockets = 02);
<i>Cam_PowerInq</i>	8x 09 04 00 FF	X0 50 0Y FF	Y : power status 2 = power ON 3 = power OFF

x = 1 to 8 (VISCA address)

X = 9 to F (VISCA address + 8)

Inquiries PT-Head

Inquiry	Packet Inquiry (Hex)	Packet Reply (Hex)	Description
<i>Pan-tiltPosInq</i>	8x 09 06 12 FF	X0 50 0Y 0Y 0Y 0Y 0Z 0Z 0Z 0Z FF	YYYY : pan position 0000h : center SW1.5 OFF : F9D0h...0630h (-360°...+360°) SW1.5 ON : FC90h...0370h (-360°...+360°) ZZZZ : tilt position 0000h : center SW1.5 OFF : FBC8h...0438h (-180°...+180°) SW1.5 ON : FED4h...012Ch. (-180°...+180°)
<i>Pan-tiltPhyPosInq</i>	8x 09 06 15 FF	X0 50 0Y 0Y 0Y 0Y 0Z 0Z 0Z 0Z FF	YYYY : pan position 0000h...0FFFh ZZZZ : tilt position 0000h...0FFFh
<i>Pan-tilt_ErrInq</i>	8x 09 05 05 FF	X0 50 0Y 00 FF	Y : 0000...1100; <i>Pan-tilt_Err</i> O.K.=0, Error=1 Bit2=pan blocking Bit3=tilt blocking; Bit2 and Bit3 are reset to 0 after register reading
<i>Pan-tilt_PwmMinInq</i>	8x 09 05 03 FF	X0 50 VV WW YY ZZ FF	VV : pan left min. PWM 00h...64h WW : pan right min. PWM 00h...64h; (PWM: 0...100% pulse width) YY : tilt down min. PWM 00h...64h ZZ : tilt up min. PWM 00h...64h; (PWM: 0...100% pulse width)

x = 1 to 8 (VISCA address)
X = 9 to F (VISCA address + 8)

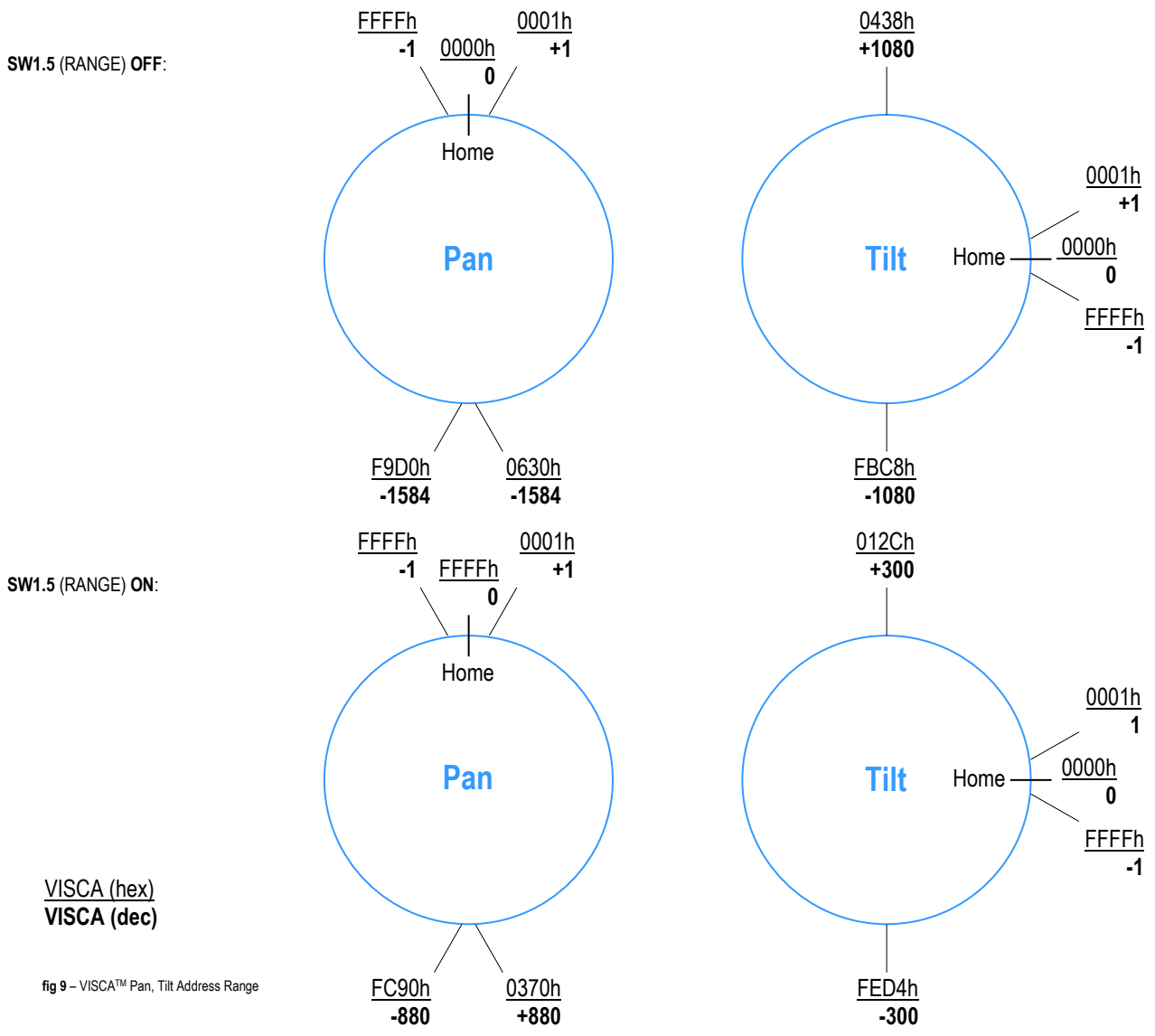

fig 9 – VISCA™ Pan, Tilt Address Range

PELCO Commands (X2, X7 PELCO – RS485)

Supported PELCO Commands

PELCO Standard Command Set

PELCO Standard Command Set*	PELCO Response	Direct Support or VISCA™ Command(s)	Comments
Pan Right	General	direct support	pan speed range: 00h...3Fh tilt speed range: 00h...3Fh
Pan Left	General	direct support	
Tilt Up	General	direct support	
Tilt Down	General	direct support	
Pan Left Tilt Up	General	direct support	
Pan Right Tilt Up	General	direct support	
Pan Left Tilt Down	General	direct support	
Pan Right Tilt Down	General	direct support	
Zoom Tele	General	<i>Cam_Zoom</i> : Tele (Standard/Variable)	Variable-speed zoom is enabled with PELCO "Set Zoom Speed" command. Standard-speed zoom is re-enabled with power OFF/ON cycle or PELCO "Reset Camera to defaults" command.
Zoom Wide	General	<i>Cam_Zoom</i> : Wide (Standard/Variable)	
Focus Far	General	<i>Cam_Focus</i> : Far (Standard/Variable)	Variable-speed focus is enabled with PELCO "Set Focus Speed" command.
Focus Near	General	<i>Cam_Focus</i> : Near (Standard/Variable)	Auto-Focus must be switched OFF before using the "Focus Far/Near" commands Standard-speed focus is re-enabled with power OFF/ON cycle or PELCO "Reset Camera to defaults" command.
Iris Open	General	<i>Cam_Iris</i> : Up (+1)	Auto-Iris must be switched OFF before using the "Iris Open/Close" commands
Iris Close	General	<i>Cam_Iris</i> : Down (-1)	
Camera ON	General	<i>Cam_Power</i> : ON	X1 (CAM POWER) X1.1 = 8...32V DCP-X05 = ON
Camera OFF	General	<i>Cam_Power</i> : OFF	X1 (CAM POWER) X1.1 = OFF DCP-X05 = OFF (stand-by)
Scan AUTO/MANUAL	X	X	

X = not supported

* PELCO Protocol allows the Transmission of Pan,Tilt,Zoom,Focus,Iris and Power Functions with only one PELCO Command. Therefore, more than one VISCA™ Command may be generated with a single PELCO-Command.

PELCO Extended Commands

PELCO Extended Command	PELCO Response	Direct Support or VISCA™ Command(s)	Comments
Set Preset (1 to 102)	General	<i>CAM_Memory: Set</i> 0 to 5	<p><i>note:</i> PELCO preset address 34(22h) is the command "Go To Zero Pan". It cannot be used as a preset.</p> <p><i>note:</i> PELCO preset address range is from 1...102(01h..66h). VISCA™ preset address range is from 0...101(00h..65h). This means that i.e. preset number 0 stored with a VISCA™ command is accessible with PELCO as preset number 1.</p> <p>PELCO Presets 1..100(01h..64h) are normal presets for the current pan-, tilt- and zoom-position. Presets 101(65h) and 102(66h) are special presets which store the current pan- and tilt-position as a virtual limit-switch. The DCP-X05 controller will not drive the pan-tilt-head above these positions if presets 101 or 102 have been set (red LED D3 is flashing).</p> <p>Preset number 101(65h) is the virtual limit switch for the maximum LEFT and DOWN position</p> <p>Preset number 102(66h) is the virtual limit switch for the maximum UP and RIGHT position</p> <p>PELCO presets 1 to 6 are using the FCB-xxx camera internal preset memory for zoom and other settings. Presets 7 to 100 are using DCP-X05 EEPROM memory for zoom.</p>
Clear Preset (1 to 102)	General	<i>CAM_Memory: Reset</i> 0 to 5	
Go To Preset (1 to 102)	General	<i>CAM_Memory: Recall</i> 0 to 5	
Flip (180°)	X	X	
Go To Zero Pan	General	direct support	Pan, Tilt Home Position
Set Auxiliary (01 to 08)	X	X	
Clear Auxiliary (01 to 08)	X	X	
Remote Reset	General	direct support	<p>calibration of pan- and tilt-axis if preset-potentiometer available. * **</p> <p><i>note:</i> voltage on preset-pins must be > 0.15V for preset-potentiometer detection (see page no.1 fig 2)</p>
Set Zone START/END	X	X	
Write Character To Screen (Column 00 to 19)	X	X	
Clear Screen	X	X	
Alarm Acknowledge	X	X	
Zone Scan ON/OFF	X	X	
Set/Run Pattern	X	X	
Set Zoom Speed (00 to 03)	General	Enables VISCA variable-speed zoom (speed: 00 to 07) with PELCO standard command set	Standard-speed zoom commands can be re-enabled with power OFF/ON cycle or command "Reset Camera to defaults"
Set Focus Speed (00 to 03)	General	Enables VISCA variable-speed focus (speed: 00 to 07) with PELCO standard command set	Standard-speed focus commands can be re-enabled with power OFF/ON cycle or command "Reset Camera to defaults"
Reset Camera to defaults	General	<i>AddressSet, IF_Clear</i>	DCP-X05 Reset, VISCA: <i>AddressSet, IF_Clear</i>
Auto-Focus AUTO/ON/OFF	General	<i>CAM_Focus: Auto ON / Auto ON / Manual</i>	Auto-Focus must be switched OFF before using the "Focus Far/Near" commands
Auto-Iris AUTO/ON/OFF	General	<i>CAM_AE: Full Auto ON / Full Auto ON / Iris Priority</i>	Auto-Iris must be switched OFF before using the "Iris Open/Close" commands
AGC AUTO/ON/OFF	X	X	
Adjust Gain	X	X	
Auto White Balance ON/OFF	X	X	
Adjust White Balance (R)	X	X	
Adjust White Balance (B)	X	X	
Adjust White Balance (M-G)	X	X	
Set Shutter Speed	X	X	
Enable Dev.Phase Del.Mode	X	X	
Adjust Line Lock Phase Delay	X	X	
Adjust Auto-Iris Level	X	X	
Adjust Auto-Iris Peak Value	X	X	
Query	Query	-	<p>PELCO Resp. ASCII Text: "DCPX5 x.x yyy z"</p> <p>"x.x" = DCP-X05 Firmware Version</p> <p>"yyy" = PELCO Address ("000...255")</p> <p>"z" = number of detected VISCA Devices (0...7)</p>
timeout=1000ms (if no reply from connected camera is received)			
Modified Query to assign new PELCO address (not standard PELCO)	Query		i.e. assigning PELCO address 03h to the DCP-X05: send PELCO packet <i>Ffh 00h 00h 45h 45h 03h 8Dh</i> to the DCP-X05 controller within 5 seconds after power-up.

* only with preset-potentiometer ** no PELCO commands are accepted during calibration

PELCO Advanced Feature Set

PELCO Advanced Feature Set	PELCO Response	Direct Support or VISCA™ Command(s)	Comments
Set Zero Position	X	X	
Set Pan Position (0 to 35999)	General	direct support	PELCO: 0000h...8C9Fh (0°...360°) 0° = Home
Set Tilt Position (0 to 35999) (9001...26999 not allowed => +90°...< -90°)	General	direct support	PELCO: 0000h...8C9Fh (0°...360°) 0° = Home 2329h...6977h not allowed => +90°...< -90° (forbidden address range is automatically adjusted to the nearest valid position)
Set Zoom Position (0 to 65535)	General	<i>Cam_Zoom: Direct</i> SW1.5 (RANGE) OFF: 0...7000h SW1.5 (RANGE) ON: 0...1023h	SW1.5 (RANGE) OFF: PELCO: 0000h...FFFFh = VISCA: 0000h...7000h SW1.5 (RANGE) ON: PELCO: 0000h...FFFFh = VISCA: 0000h...1023h
Query Pan Position (0 to 35999)	Extended	direct support	PELCO: 0000h...8C9Fh = 0°...360° 0° = Home
Query Tilt Position (0 to 35999)	Extended	direct support	PELCO: 0000h...8C9Fh = 0°...360° 0° = Home
Query Zoom Position (0 to 65535) timeout=1000ms (if no reply from connected camera is received)	Extended	<i>Cam_ZoomPosInq:</i> SW1.5 (RANGE) OFF: 0...7000h SW1.5 (RANGE) ON: 0...1023h	SW1.5 (RANGE) OFF: PELCO: 0000h...FFFFh = VISCA: 0000h...7000h SW1.5 (RANGE) ON: PELCO: 0000h...FFFFh = VISCA: 0000h...1023h
Query Pan Response	X	X	
Query Tilt Response	X	X	
Query Zoom Response	X	X	
Set Magnification	X	X	
Query Magnification	X	X	
Query Magnification Response	X	X	

X = not supported

fig 10 – PELCO Pan,Tilt Address Range

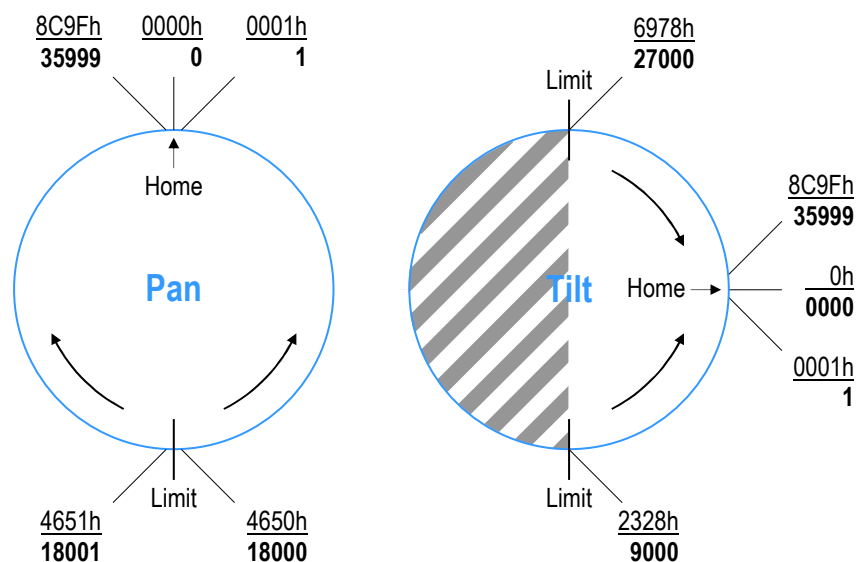

PELCO (hex)
PELCO (dec)

 PELCO Range
9001 ... 26999
not allowed!

Specifications
General

Dimensions	64 x 64 x 14 mm
Mounting	4x 3.2mm hole (3x connected to GND)
Operating temperature/humidity	-25°C to +50°C, 20% to 75% relative humidity
Weight	100g

Power (POWER1 X2, POWER2 X3)

Supply voltage	8 ... 32V DC
Current min. (POWER1)	~10mA@24V (<i>Cam_Power Off</i>)
Current min. (POWER2)	~13mA@24V (<i>Cam_Power Off</i>)
Current max. (all motors off)	~25mA@24V (<i>Cam_Power On</i>)
Current max. (motors on)	3A (fused – non-resettable)



The current of all outputs in total (X5 PT-MOTORS and X1 CAM POWER) must not exceed 3A. The DCP-X05 controller has non-resettable 3A (fast blow.) input fuses for protection.

Camera Power Output (X1)

Camera supply voltage	8 ... 32V DC (X2.1, X3.1)
Camera current max.	1A (power ON)
Short-circuit protection	no (3A non-resettable input fuse)

VISCA™ RS232 Interface (X7)

Speed	9600 Baud
Startbits	1
Databits	8
Stopbits	1
Parity	no
Handshake	no
Timeout	500ms
TTL TxD (X7.4)	3.3V
TTL RxD (X7.4)	3.3V (5V tolerant)
Protocol	VISCA™

PELCO RS485 Interface (X7, X2)

Speed	9600 Baud
Startbits	1
Databits	8
Stopbits	1
Parity	no
Handshake	no
Timeout	500ms
Protocol	PELCO-D (Standard, Extended, Advanced)
Configuration	2-wire (simplex)

USB Interface (X8)

Connector	Mini-USB
Mode	device
Speed	USB 2.0
Vendor ID	0x0400
Product ID	0x0003
Power	bus powered
Consumption	max. 100mA
Protocol	HID communication HID bootloader

A/D-Converter (Pan, Tilt)

Input voltage	0.15 ... 2.048V
Resolution	12 Bit
Measurement error	± 1 LSB
Input resistance	470kΩ
Recommended Preset-potentiometer	1 ... 10kΩ

PT-Head Motors

Pan current max.	3A
Pan switch-on time limitation	360s (without preset-potentiometer)
Tilt current max.	3A
Tilt switch-on time limitation	360s (without preset-potentiometer)
PWM frequency	20kHz
Overcurrent protection	yes
Short-circuit protection	yes
Undervoltage lockout	yes
Overtemperature protection	yes

Recommended PT-Head

Current	≤3A/axis
End stops	necessary for calibration procedure with preset-potentiometers
Preset-potentiometers	free accessible 3-pin connection or max. 2.048V output

Dimensions

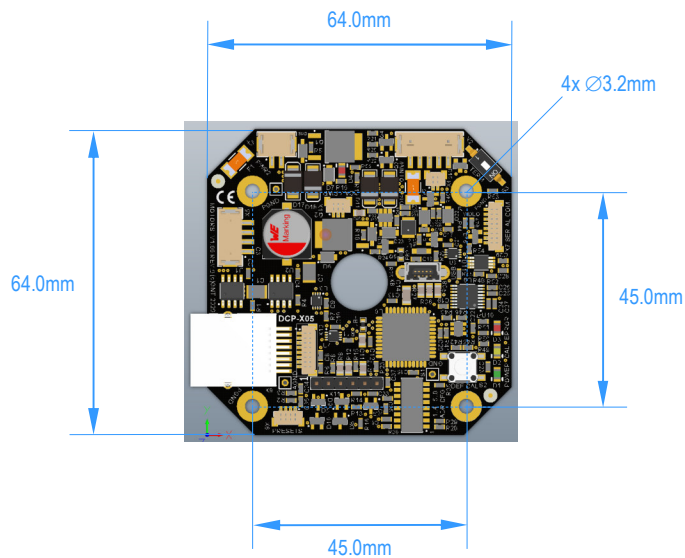

fig 11 – DCP-X05 Mounting

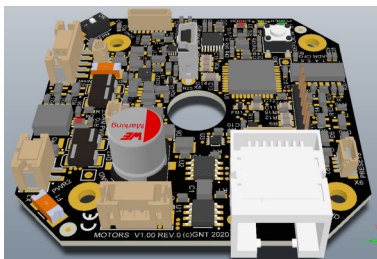

fig 12 – DCP-X05 Front-View